

MAH22PR

MAYTAG® COMMERCIAL
ENERGY ADVANTAGE™
HIGH-EFFICIENCY FRONT-LOAD WASHERS



* Shown with optional pedestal.

**SAVE UP
TO 60%
EVERY YEAR*
ON ENERGY,
WATER AND
SEWER
COSTS.**

- ▶ **MODIFIED ENERGY FACTOR 2.35**
- ▶ **WATER FACTOR 4.4**
- ▶ **CEE TIER III**

LEGENDARY MAYTAG DEPENDABILITY

Maximizing your equipment investment for over a half century.



Built with optional non-metered design.

A COMPLETE LINE OF ENERGY-EFFICIENT SOLUTIONS

Maytag built the first appliance ever to receive the ENERGY STAR® label. Today we offer a complete line of high-efficiency commercial laundry appliances — from energy-efficient dryers to highly efficient ENERGY STAR®-qualified washers — to help you save money and build profits.

FOR YOUR CUSTOMERS:

- Large Capacity For Bulky Items
- High-Speed Extraction Cuts Drying Time
- Extra-Large Door Opening
- Easy-To-Use One-Touch Cycle Selection
- Flexible Wash Options
- Time Remaining Display
- Automatic Detergent, Softener And Bleach Dispenser
- Large Windows For Convenience
- Front Controls For Ease-Of-Use
- ADA Compliant With Optional Pedestal
- No Need To Carry Quarters

FOR YOUR OPERATION:

- High Efficiency Design Offers Significant Utility Savings
- Super Cycle Option Increases Revenue
- Self-Diagnostic Feature Cuts Service Cost And Minimizes Downtime
- Accu Trac® Audit System With Two-Way Data Communication
- Debit Card Compatibility
- Advanced Computer Trac® Controls Allow For Easy Programming
- Simple Soft-Mount Design For Easy Installation

BUILT-TO-LAST™ FEATURES:

- Porcelain-Enamel Top With Backsplash
- Precision Endurance Drive
- Controlled Induction Motor
- Best Warranty In The Business

LAUNDRY SOLUTIONS
YOU CAN *DEPEND ON.*

* Based on AHAM load sizes. Individual savings may vary.

CLP800



OUR COMMITMENT TO DEPENDABLE QUALITY

At Maytag, we believe durable goods should remain just that. That's why every Maytag® product is constructed of the highest-quality materials and with the utmost in precision craftsmanship. It's also why we stand behind our equipment with solid service and support from our professional Maytag laundry suppliers. Simply put, when you choose Maytag® products, you ensure your peace of mind.

www.maytagcommerciallaundry.com



MAH22PR

MAYTAG® COMMERCIAL ENERGY ADVANTAGE™ HIGH-EFFICIENCY FRONT-LOAD WASHERS

Maytag® Energy Advantage™ Front-Load Washer MICROPROCESSOR CARD READER-READY

WASHER SPECIFICATIONS	
MODEL	MAH22PR
MOTOR	
Variable-speed, reversible, thermoprotected, high-efficiency, controlled induction	•
Wash — HP (kw)	.09 (.07)
Extract — HP (kw)	.54 (.40)
Average kilowatt per cycle	.08
APPROXIMATE WATER USAGE — gallons (liters)	
Average hot water usage, hot water cycle	3.5 (13.2)
Average hot water usage, warm water cycle	1.8 (6.8)
Average total water usage per cycle	13.1 (49.6)*
ELECTRICAL RATING	
Domestic model — voltage	120V/60 Hz
Export model — voltage	220-240V/50Hz
BREAKER/FUSE REQUIREMENTS	
Domestic model — amps	15
Export model — amps	10
CYLINDER	
Volume — cu. ft. (liters)	2.99 (84.7)
Diameter — in. (mm)	21.6 (547)
Depth — in. (mm)	13.4 (341)
DOOR OPENING	
In. (mm)	14.2 (361)
WASH SPEED	
RPM	40
EXTRACT SPEED	
Maximum rpm	1,000
Maximum g-force	306
OPERATING PRESSURE	
Psi (bar)	20-100 (1-8)
INLET HOSE	
Ft. (m)	4 (1.22)
DRAIN HOSE	
Ft. (m)	6 (1.83)
ADJUSTABLE LEVELING LEGS	•
APPROXIMATE WEIGHT	
Crated — lbs. (kg)	249 (112.9)
Uncrated — lbs. (kg)	234 (106.1)
DIMENSIONS	
Width — in. (mm)	27 (685.8)
Depth — in. (mm)	29 (736.6)
Height — in. (mm)	37.85 (961.4)**

* Average based on JI testing with factory preset cycles.
** Height at backsplash top does not include pedestal.
Dimensions are for planning purposes only. See specific instructions for proper installation. Because of continuous product improvement, Maytag reserves the right to change specifications without notice.

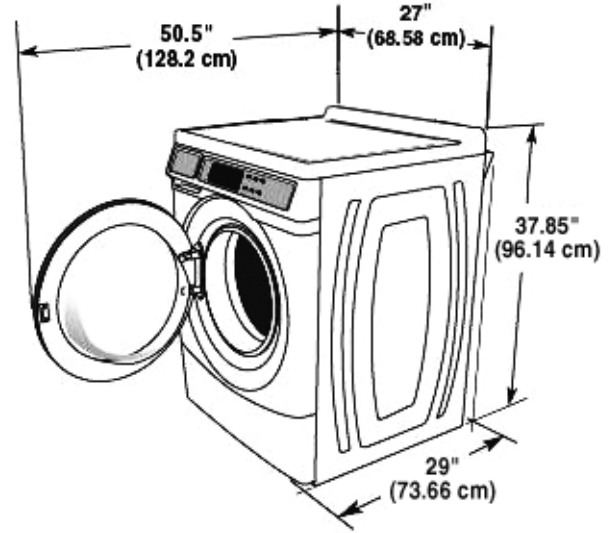

5 YEARS ON ALL PARTS

For a period from the date of original purchase through the time listed above, the designated parts that fail in normal commercial use will be repaired or replaced free of charge for the part itself, with the owner paying all other costs, including labor, transportation and customs duty. Chemical damage is excluded from all warranty coverage. See complete warranty for details.